

# DIRECT DIFFUSE® STEAM TRAP

**Failed steam traps are inefficient and not having steam traps are operationally unsafe; both can waste fuel and energy, increase production costs, and weaken the steam system.**

Multiple steam trap designs are often needed to handle various loads within a steam system. Many traps rely on a mechanical valve to open and close to release condensate, but fluctuations in the load of condensate cannot be compensated for and therefore, will result in a deficient operation. Systems without a steam trap can have serious impact on pipe fittings and valves that may shatter from the high speed and weight of condensate traveling through the system.

**Our Direct Diffuse® Steam Trap mounts in-line to quickly and efficiently discharge condensate in your steam line.**

Our patented system is the only kind on the market. Our traps don't require a trunk line—they are mounted directly in the flow pipe; this means that our system works more efficiently directing the steam in your line with no valves or other moving parts through a collection, which means nothing to replace or wear down, ensuring a long life.

- no moving parts to wear out
- compact design
- horizontal or vertical installation
- reduces condensate in the steam lines
- improves efficiency of your steam system
- cost-effective compared to other steam traps
- 1 year limited warranty

PATENT NO. US 10,550,999  
CRN 0E22109.5



Installation horizontal  
OR vertical.

The Thermodynamic Trap (THT) must be installed level in the horizontal plane.

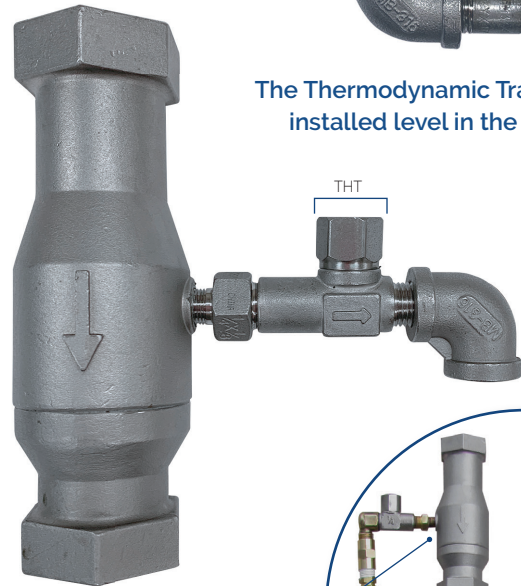

Direct Diffuse® Steam Trap shown here is installed vertically on a Strahman M-5000TG Mixing Unit.

# DIRECT DIFFUSE® STEAM TRAP

## How Our System Works

### Innovative design separates condensate from steam.

When the steam and condensate enters the trap inlet, it forms droplets under pressure. The steam and condensate droplets separate as the mixture passes the diffuser cone. The heavier condensate droplets gain speed and drain downward to the condensate accumulation chamber where they then flow to the thermodynamic trap, which acts similar to a check valve, releasing condensate as water back to your condensate return line or a drain. Steam, having less weight, is directed upward as the chamber narrows then enters back into the line without condensate.

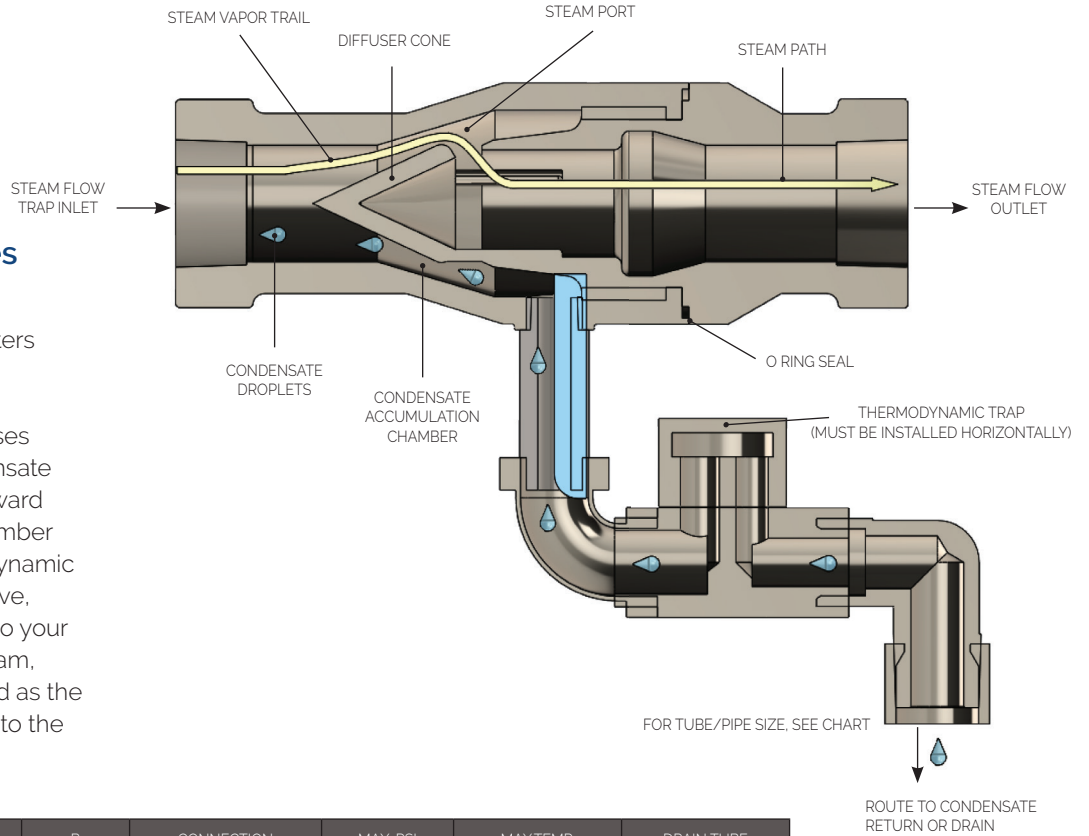

ORDER NO.	PIPE DIAMETER	A	B	CONNECTION	MAX. PSI	MAX.TEMP.	DRAIN TUBE
DDITRAP	¾"	5 ¾"	4"	¾" - 14 NPT	150	350°F (175°C)	¼" TUBE

## Installation Instructions:

1. Shut off water and steam supply.
2. Allow pipes to cool.
3. Connect NPT Pipe to the Steam Line.
4. Make sure the flow direction arrow points downstream away from source and toward the point of use.
5. Route condensate drain piping to the appropriate system.

### HORIZONTAL INSTALLATION

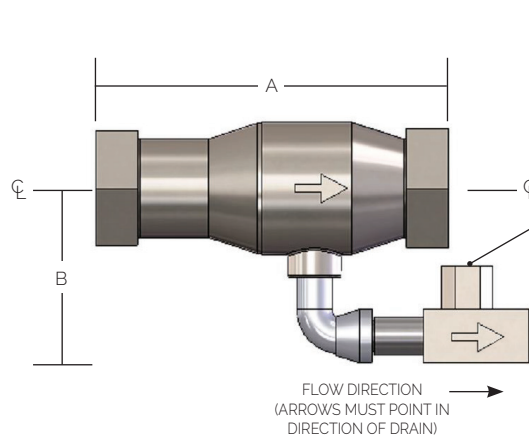

### VERTICAL INSTALLATION

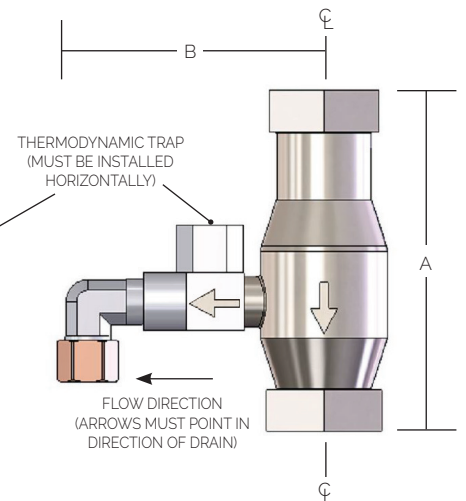

PATENT NO. 10550999

CRN 0E22109.5

© STRAHMAN GROUP | PUBLISHED 112324